



Public View Display w/ **WDR Built in Camera**

SPECIAL FEATURES

- Built-In WDR 1/3" Sony Super HAD double SCAN CCD
- All Front Acrylic LCD Protective Shield
- 3D Comb Filter, Deinterlace, Noise Reduction, Auto Source Sequencing
- 1600 x 1200 Resolution, 300 Nits, 800:1 Contrast
- 2.8 ~ 12mm Vari-Focal Lens(F=1.5)
- 560 TV Line Horizontal Resolution
- PIP / PBP Multi Display Function
- Optional Mounts: Wall or Ceiling Mount Kits

SPECIFICATIONS

		20PVMV
Display	Screen Size	20.1 Inch
	Max. Resolution	1600 x 1200 @ 60Hz
	Pixel Pitch	0.255 x 0.255mm
	Brightness	300cd/m ²
	Contrast Ratio	800 : 1
	Aspect Ratio	4 : 3
	Viewing Angle	178° / 178°
	Display Color	16.7 Million
	Response Time	< 18ms
Video System	NTSC / PAL	
Interface	Video In / Out (BNC Type)	1 / 2 (Include Camera Out)
	S-Video In	1
	HDMI In	2
	VGA In (15Pin D-Sub)	1
	Audio In (RCA Type)	1 (L+R)
	PC Stereo In	
Transmitter	Remote Control	Yes
Audio	Built-in Speakers	Yes (2W x 2)
	Filter Type	3D Comb Filter / Deinterlacing / Noise Reductio
Features	Multi Display Function	PIP / PBP
	LCD Protection	All Front Acrylic Shield
	Multi Language	English, Spanish, French, German, Italian
	Auto Source Sequencing	Yes
	Motion Sensor	Microwave Motion Sensor (10 ~ 30 feet)
Dimension	Outline Dimension (W x H x D)	18.93"(W) x 18.02"(H) x 2.92"(D)
	Net. Weight	9.3Kg (20.5lbs)
Cabinet	Material / Color	Electronic galvanized Iron / Black, White (Optional)
Warranty	Part/Labor	2year / 2year
	MTBF (Approx.)	50,000 Hours
Regulations		RoHS, TUV-NRTL(=UL), CB, FCC(A), CE-Emc(LVD)
Power	Consumption: < On	< 60W
	Electrical Ratings	AC100 ~ 240V(50/60Hz) DC 12V / 5A
Circumstance	Operating Temperature	0 ~ 50° C / 32 ~ 122° F
	Storage Temperature	-20 ~ 60° C / -4 ~ 140° F
Camera	Camera Type	WDR Camera
	Mechanical Design	Tilt Swivel Camera
	Scanning System	2 : 1 interface
	Image Sensor	1/3" Sony Super HAD double SCAN CCD
	WDR Control	60dB
	Resolution	Horizontal: 560TV Lines
	Lens Mount	2.8 ~ 12mm Vari-Focal Lens(F=1.5)
	Sensitivity	0.4 Lux (50 IRE) with F1.2 Lens, 0.001 Lux (50 IRE) Sense-up x 256
	Electronic Shutter	1/60 ~ 1/10,000 Sec.
	VESA™ Mount Size	100 x 100mm (BS M4 x 10mm Screw)
Mounts	Wall	WB-05, WB-10, WB-30, WB-31
	Ceiling	CMK-01

*Design and specifications are subject to change without notice

DIMENSIONS

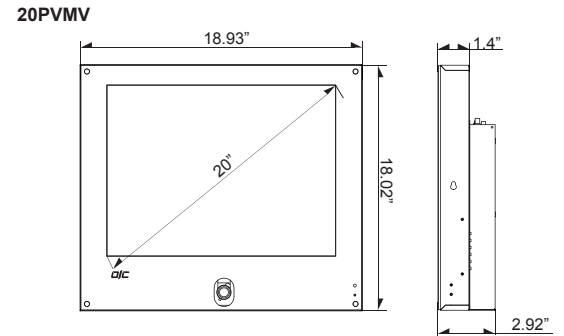

WHERE TO USE

PVMV can be used in Restaurant, Grocery Store, Casino, School, Financial Institute, Dealership, Department Store, Convenience Store, Mall, Transportation, Airport, Public Arena, High Technology Store and etc...



PVMV installed ceiling mount

Rear Quarter View